

PR[®]



6 3 3 3

**2-Wire Programmable
Transmitter**

No. 6333V103-I N
From ser. no. 080629052

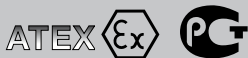

SIGNALS THE BEST

- DK** ▶ PR electronics A/S tilbyder et bredt program af analoge og digitale signalbehandlingsmoduler til industriel automation. Programmet består af Isolatorer, Displays, Ex-barrierer, Temperaturtransmittere, Universaltransmittere mfl. Vi har modulerne, du kan stole på i selv barske miljøer med elektrisk støj, vibrationer og temperaturudsving, og alle produkter opfylder de strengeste internationale standarder. Vores motto »Signals the Best« er indbegrebet af denne filosofi – og din garanti for kvalitet.
- UK** ▶ PR electronics A/S offers a wide range of analogue and digital signal conditioning modules for industrial automation. The product range includes Isolators, Displays, Ex Interfaces, Temperature Transmitters, and Universal Modules. You can trust our products in the most extreme environments with electrical noise, vibrations and temperature fluctuations, and all products comply with the most exacting international standards. »Signals the Best« is the epitome of our philosophy – and your guarantee for quality.
- FR** ▶ PR electronics A/S offre une large gamme de produits pour le traitement des signaux analogiques et numériques dans tous les domaines industriels. La gamme de produits s'étend des transmetteurs de température aux afficheurs, des isolateurs aux interfaces SI, jusqu'aux modules universels. Vous pouvez compter sur nos produits même dans les conditions d'utilisation sévères, p.ex. bruit électrique, vibrations et fluctuations de température. Tous nos produits sont conformes aux normes internationales les plus strictes. Notre devise »SIGNALS the BEST« c'est notre ligne de conduite - et pour vous l'assurance de la meilleure qualité.
- DE** ▶ PR electronics A/S verfügt über ein breites Produktprogramm an analogen und digitalen Signalverarbeitungsmodulen für die industrielle Automatisierung. Dieses Programm umfasst Displays, Temperaturtransmitter, Ex- und galvanische Signaltrenner, und Universalgeräte. Sie können unsere Geräte auch unter extremen Einsatzbedingungen wie elektrisches Rauschen, Erschütterungen und Temperaturschwingungen vertrauen, und alle Produkte von PR electronics werden in Übereinstimmung mit den strengsten internationalen Normen produziert. »Signals the Best« ist Ihre Garantie für Qualität!

2-WIRE PROGRAMMABLE TRANSMITTER

PRetrans 6333

Contents

EC declaration of conformity	2
Application	3
Technical characteristics	3
Mounting / installation.....	3
Applications.....	4
Order: 6333	5
Electrical specifications.....	5
Connections	8
Block diagram	9
Programming.....	10
Appendix	11
ATEX Installation Drawing - 6333A.....	12
ATEX Installation Drawing - 6333B	13

EC DECLARATION OF CONFORMITY

As manufacturer

**PR electronics A/S
Lerbakken 10
DK-8410 Rønde**

hererby declares that the following product:

**Type: 6333
Name: 2-Wire programmable transmitter**

is in conformity with the following directives and standards:

The EMC Directive 2004/108/EC and later amendments

EN 61326-1 : 2006

For specification of the acceptable EMC performance level, refer to the electrical specifications for the module.

The ATEX Directive 94/9/EC and later amendments

EN 60079-0 : 2006, EN 60079-11 : 2007,

EN 60079-15 : 2005 and EN 60079-26 : 2007

ATEX certificate: KEMA 10ATEX0007 X (6333A)

ATEX certificate: KEMA 09ATEX0147 (6333B)

Notified body

**KEMA Quality B.V. (0344)
Utrechtseweg 310, 6812 AR Arnhem
P.O. Box 5185, 6802 ED Arnhem
The Netherlands**

Rønde, 10 February 2010



Kim Rasmussen
Manufacturer's signature

2-WIRE PROGRAMMABLE TRANSMITTER PRetrans 6333

- *RTD or Ohm input*
- *High measurement accuracy*
- *3-wire connection*
- *Programmable sensor error value*
- *1- or 2-channel version*

Application

- Linearised temperature measurement with Pt100...Pt1000 or Ni100...Ni1000 sensor.
- Conversion of linear resistance variation to a standard analogue current signal, for instance from valves or Ohmic level sensors.

Technical characteristics

- Within a few seconds the user can program PR6333 to measure temperatures within all RTD ranges defined by the norms.
- The RTD and resistance inputs have cable compensation for 3-wire connection.
- A limit can be programmed on the output signal.

Mounting / installation

- Mounted vertically or horizontally on a DIN rail. Using the 2-channel version up to 84 channels per metre can be mounted.
- **NB:** As Ex barrier for 6333B we recommend 5104B, 5114B, or 5116B.

APPLICATIONS

RTD to 4...20 mA

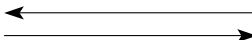

2-wire installation
in control room



Resistance
to 4...20 mA

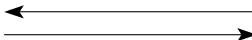

2-wire installation
in control room



Order: 6333

Type	Version	Galvanic isolation	Channels
6333	Standard : A ATEX Ex : B	None : 1	Single : A Double : B

Electrical specifications

Specifications range:

-40°C to +60°C

Common specifications:

Supply voltage, DC

Standard..... 8...35 VDC

ATEX Ex..... 8...30 VDC

Internal consumption 0.19...0.8 W

Voltage drop 8 VDC

Isolation voltage, channel 1 / channel 2:

Standard..... 3.75 kVAC

ATEX Ex..... 1500 VAC

Warm-up time..... 5 min.

Communications interface Loop Link

Signal / noise ratio Min. 60 dB

Response time (programmable)..... 0.33...60 s

Signal dynamics, input..... 19 bit

Signal dynamics, output..... 16 bit

Calibration temperature..... 20...28°C

Accuracy, the greater of general and basic values:

General values		
Input type	Absolute accuracy	Temperature coefficient
All	≤ ±0.1% of span	≤ ±0.01% of span / °C

Basic values		
Input type	Basic accuracy	Temperature coefficient
RTD	$\leq \pm 0.3^{\circ}\text{C}$	$\leq \pm 0.01^{\circ}\text{C}/^{\circ}\text{C}$
Lin. R	$\leq \pm 0.2 \Omega$	$\leq \pm 20 \text{ m}\Omega / ^{\circ}\text{C}$

EMC immunity influence $< \pm 0.5\%$ of span

Effect of supply voltage variation..... $\leq 0.005\%$ of span / VDC
 Max. wire size..... $1 \times 1.5 \text{ mm}^2$ stranded wire
 Humidity $< 95\%$ RH (non-cond.)
 Dimensions (H x W x D) $109 \times 23.5 \times 104 \text{ mm}$
 Protection degree..... IP20
 Weight (1 / 2 channels)..... $145 / 185 \text{ g}$

Electrical specifications, inputs:

Max. offset..... 50% of selec. max. value

RTD and linear resistance inputs:

RTD type	Min. value	Max. value	Min. span	Standard
Pt100	-200°C	$+850^{\circ}\text{C}$	25°C	IEC 60751
Ni100	-60°C	$+250^{\circ}\text{C}$	25°C	DIN 43760
Lin. R	0Ω	10000Ω	30Ω	-----

Cable resistance per wire (max.)..... 10Ω
 Sensor current..... $> 0.2 \text{ mA}, < 0.4 \text{ mA}$
 Effect of sensor cable resistance
 (3-wire)..... $< 0.002 \Omega / \Omega$
 Sensor error detection Yes

Outputs:

Current outputs:

Signal range $4 \dots 20 \text{ mA}$
 Min. signal range..... 16 mA
 Updating time..... 135 ms
 Load resistance..... $\leq (V_{\text{supply}} - 8) / 0.023 [\Omega]$
 Load stability..... $< \pm 0.01\%$ of span / 100Ω

Sensor error detection:

Programmable..... $3.5 \dots 23 \text{ mA}$
 NAMUR NE43 Upscale 23 mA
 NAMUR NE43 Downscale..... 3.5 mA

Of span = Of the presently selected range

Ex approval - 6333A:

KEMA 10ATEX0007 X.....	II 3 G Ex nA [nL] IIC T4...T6 or II 3 G Ex nL IIC T4...T6 or II 3 G Ex nA [ic] IIC T4...T6 or II 3 G Ex ic IIC T4...T6
ATEX Installation Drawing No.....	6333QA02

Ex / I.S. approval - 6333B:

KEMA 09ATEX0147	 II 1 G Ex ia IIC T6...T5
Max. amb. temperature for T6	40°C
Max. amb. temperature for T5	60°C
ATEX, applicable in zone.....	0, 1 or 2
ATEX Installation Drawing No.	6333QA01

GOST R approval:

VNIIM & VNIIFTRI, Cert. no. See www.preelectronics.com

Observed authority requirements:**Standard:**

EMC 2004/108/EC	EN 61326-1
ATEX 94/9/EC.....	EN 60079-0, EN 60079-11, EN 60079-15, EN 60079-26

CONNECTIONS

Inputs:

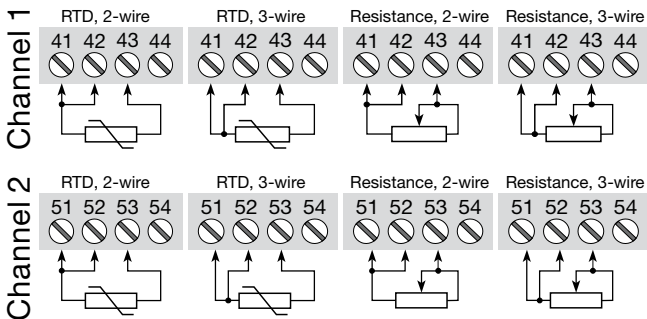

Outputs:

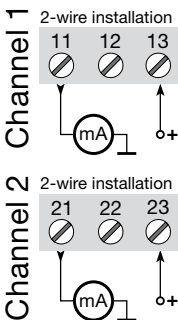

BLOCK DIAGRAM

PROGRAMMING

- Loop Link is a battery-powered communications interface that is needed for programming PRetrans 6333.
- For programming please refer to the drawing below and the help functions in PReset.
- When communicating with non-installed modules, connectors 11, 12, 13 (channel 1) and 21, 22, 23 (channel 2) can be dismantled to connect the terminals of the communications interface to the pins.
- Loop Link is not approved for communication with modules installed in hazardous (Ex) area.

Order: Loop Link

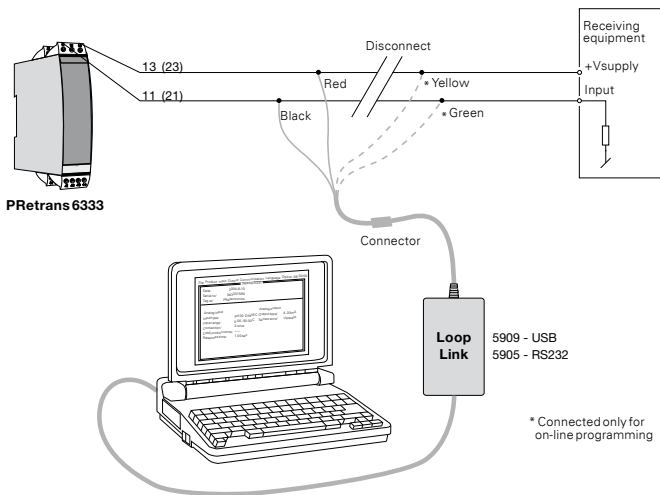

APPENDIX

ATEX INSTALLATION DRAWING - 6333A

ATEX INSTALLATION DRAWING - 6333B

ATEX Installation drawing

For safe installation of 6333A the following must be observed. The module shall only be installed by qualified personnel who are familiar with the national and international laws, directives and standards that apply to this area.

Year of manufacture can be taken from the first two digits in the serial number.

ATEX Certificate KEMA 10ATEX 0007X

Marking  II 3 G Ex nA [nL] IIC T6..T5
 II 3 G Ex nL IIC T6..T5
 II 3 G Ex nA [ic] IIC T6..T5
 II 3 G Ex ic IIC T6..T5

Standards EN 60079-0 : 2006, EN 60079-11 : 2007, EN 60079-15 : 2005

T5: -40°C to 60 °C
 T6: -40°C to 40 °C

Terminal:
41,42,43 /
51,52,53

Ex nA [nL]

Uo: 27 VDC
 Io: 7.0 mA
 Po: 45 mW
 Lo: 35 mH
 Co: 90 nF

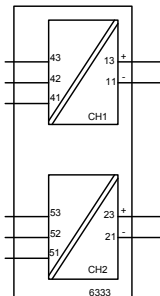

Hazardous Area Zone 2

Terminal:
11-13 / 21-23

Ex nA

U ≤ 35 VDC
 I = 4 - 20 mA

Ex nL or Ex ic

Ui = 35 VDC
 Li = 10 μH
 Ci = 1.0 nF

Special conditions for safe use

For use in a potentially explosive atmosphere of flammable gasses, vapours or mists, the transmitter shall be mounted in an enclosure providing a degree of protection of at least IP54 in accordance to EN60529.

ATEX Installation drawing

6333

For safe installation of 6333B the following must be observed. The module shall only be installed by qualified personnel who are familiar with the national and international laws, directives and standards that apply to this area.

Year of manufacture can be taken from the first two digits in the serial number.

ATEX Certificate KEMA 09ATEX 0147

Marking II 1 G Ex ia IIC T6..T5

Standards EN 60079-0 : 2006, EN 60079-11 : 2007, EN 60079-26 : 2007

Hazardous area
Zone 0, 1, 2

T5: $-40 \leq T_a \leq 60^\circ\text{C}$
T6: $-40 \leq T_a \leq 40^\circ\text{C}$

**Terminal:
41,42,43**

U_o: 27 VDC
I_o: 7 mA
P_o: 45 mW
L_o: 35 mH
C_o: 90 nF

**Terminal:
51,52,53**

U_o: 27 VDC
I_o: 7 mA
P_o: 45 mW
L_o: 35 mH
C_o: 90 nF

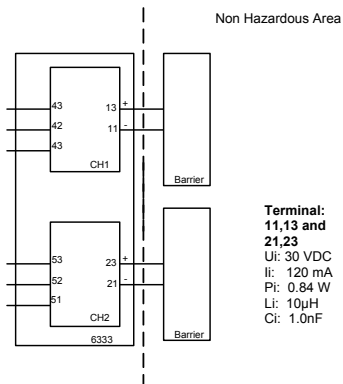

**Terminal:
11,13 and
21,23**

U_i: 30 VDC
I_i: 120 mA
P_i: 0.84 W
L_i: 10µH
C_i: 1.0nF

Installation notes.

The instructions provided with the equipment shall be followed in detail in order to assure safe operation.



Displays Programmable displays with a wide selection of inputs and outputs for display of temperature, volume and weight, etc. Feature linearisation, scaling, and difference measurement functions for programming via PReset software.



Ex interfaces Interfaces for analogue and digital signals as well as HART® signals between sensors / I/P converters / frequency signals and control systems in Ex zone 0, 1 & 2 and for some modules in zone 20, 21 & 22.



Isolation Galvanic isolators for analogue and digital signals as well as HART® signals. A wide product range with both loop-powered and universal isolators featuring linearisation, inversion, and scaling of output signals.



Temperature A wide selection of transmitters for DIN form B mounting and DIN rail modules with analogue and digital bus communication ranging from application-specific to universal transmitters.



Universal PC or front programmable modules with universal options for input, output and supply. This range offers a number of advanced features such as process calibration, linearisation and auto-diagnosis.





www.preelectronics.fr



sales@preelectronics.fr



www.preelectronics.de



sales@preelectronics.de



www.preelectronics.es



sales@preelectronics.es



www.preelectronics.it



sales@preelectronics.it



www.preelectronics.se



sales@preelectronics.se



www.preelectronics.co.uk



sales@preelectronics.co.uk



www.preelectronics.com



sales@preelectronics.com

Head office

Denmark
PR electronics A/S
Lerbakken 10
DK-8410 Rønne

www.preelectronics.com
sales@preelectronics.dk
tel. +45 86 37 26 77
fax +45 86 37 30 85



QUALITY SYSTEM AND ENVIRONMENTAL MANAGEMENT SYSTEM
DS/EN ISO 9001
DS/EN ISO 14001

